



**M450s**  
SKID STEER  
MULCHER



# M450s

The M450s mulcher is designed for the compact loader segment or other hydraulic-driven carriers.

Developed for a range of carrier vehicles from 70 – 180 hp and a volume flow between 22.5 – 66 gpm (85 – 250 l/min) the M450s is a compact and powerful head for a diversity of mulching applications.

## Benefits for you

- + Perfect visibility
- + Lightweight
- + Plug and Mulch
- + Powerful



### Lightweight

A lightweight mulching head provides more safety. The point of gravity is close to the carrier which means it provides easier handling and less tipping or roll over danger.



### Plug and Mulch

Hydraulic hoses with standard fittings are included in the package and already delivered from factory. The M450s is well prepared for Plug and Mulch.

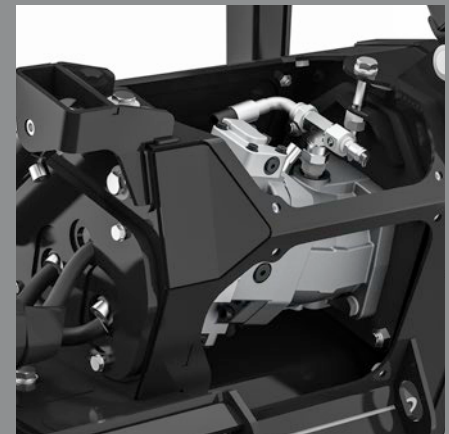

### Powerful

The M450s is equipped with a strong 115 cc Rexroth HD variable axial piston motor. The strong polybelt with 2.7 in (68 mm) transfers the power to the rotor. The low maintenance polybelt concept saves valuable time.



## UPTs Rotor Tools

TECHNICAL DATA	1600	1900	2200
Power range	70 – 150 hp	80 – 150 hp	100 – 180 hp
Volume flow	22.5 – 52.8 gpm (85 – 200 l/min)	24.6 – 52.8 gpm (100 – 200 l/min)	31.7 – 66 gpm (120 – 250 l/min)
Variable HD displacement piston motor	115 cc	115 cc	115 / 170 cc
Tools	32x BCS / 42x UPTs	40x BCS / 48x UPTs	48x BCS / 56x UPTs
Working width	63 in (1600 mm)	74.8 in (1900 mm)	86.8 in (2200 mm)
Total width	74.8 in (1900 mm)	86.6 in (2200 mm)	98.4 in (2500 mm)
Weight*	2513 lbs (1140 kg)	2668 lbs (1210 kg)	3042 lbs (1380 kg)

\* Weight depending on the configuration of the machine optional with or without a flap



### UPTs02

Finest and most consistent mulch results through double-tip knife geometry, recommended use for wood and limited rock.



### UPTs04

Extremely aggressive tool with best penetration, very low power requirement, additional carbide plates for abrasive ground conditions, wide range of applications.



### UPTs07

Extremely shock resistant in rocky ground, all-around reliability.



### UPTs05/06

Side scraper to protect outer tool holders and clear remnants between rotor and housing. Unique carbide pattern at the outer edges, left or right version.



### UPTs08 + BCS03

UPTs-holder for BCS03 tools, one-edged chipper blade with hardened surface for above-ground mulching.

## BCS Rotor Tools



### BCS02

Triple-carbide tool with main cutting tip in the center, side tips set diagonally to reduce power requirement, for wear-intensive and sandy applications. Additional protection of tool holder through wider carbide tips at the side.



### BCS03

One-edged chipper blade with hardened surface for above-ground mulching, mounted on standard BCS holder.



### BCS Bite-Control-System

BCS-Rotor with steel knives or carbide teeth. Best balanced rotor for less wear on bearings and high speed meaning high productivity and perfect finishing.

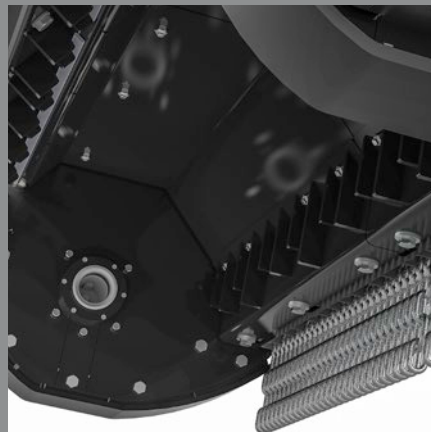

### Counter blades

The housing of the M450s is equipped standard with liners with two rows of counter blades. The liners are made out of highly wear-resistant steel.

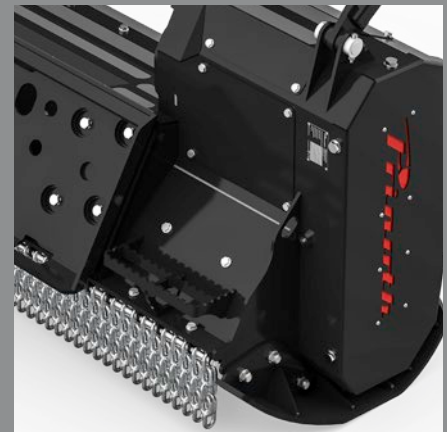

### Maximum Safety

For maximum safety the M450s is equipped with anti-slip stripes on top of the housing with two steps for a safe access to the carrier.





Sales and service sites in your area can be found on [www.prinoth.com](http://www.prinoth.com)

PRINOTH GmbH  
Im Branden 15  
88634 Herdwangen  
GERMANY  
Phone: +49 7557 92120  
[prinoth.germany@prinoth.com](mailto:prinoth.germany@prinoth.com)

PRINOTH AG  
Brennerstraße 34  
39049 Sterzing  
ITALY  
Phone: +39 0472 72 26 22  
[prinoth@prinoth.com](mailto:prinoth@prinoth.com)

PRINOTH Ltd.  
1001, J.-A. Bombardier Street  
Granby Qc J2J 1E9  
CANADA  
Phone: +1 450 776 3600  
[sales.na@prinoth.com](mailto:sales.na@prinoth.com)